



Professional water treatment.

2019/2020 Product Catalogue

watersystem

Professional water treatment.

Water is the most important element of life as it enables us to function. In the food service industry, water is critical to the quality, taste and smell of meals served. Moreover, water quality has a significant impact on the lifetime of equipment, including dish washers, combi-steam ovens or coffee makers.

Through the use of a suitable water filtration system, you show care towards your customers while saving money. The Watersystem team carefully selects latest technological solutions and innovations to meet the ever-changing needs of the the market.

Our company, WATERSYSTEM Sp. z o.o. Sp. k, has been specialising in water treatment solutions for domestic and industrial use for over 15 years. We apply our expertise to guarantee the highest quality of service and products.

Take a look at our latest range of water filtration and softening systems and compact devices utilising the phenomenon of reverse osmosis.

We are looking forward to doing business with you.

Marek Sobolewski





Our filters protect against:

- corrosion of metal components
- limescale and persistent sediments
- the harmful impact of chlorine and other chemical substances
- unpleasant water odours
- contamination by heavy metals and petroleum products

Our filters ensure:

- full protection of your equipment
- a great taste of water
- high-quality and clear water in ice cubes
- coffee and tea with full aroma and without sediment
- the highest quality of meals served to your guests
- shiny cutlery and plates, always without streaks and without polishing
- superior quality and protection of water

ONE FILTERS

- ONE C
- ONE MB
- ONE MG+
- ONE SOFT
- ONE UF
- ONE LEAD

ONE FILTERS

ADVANTAGES

APPLICATIONS

TECHNICAL SPECIFICATIONS

ONE C

ONE C is a versatile solution for water treatment in food service. The ONE C filter improves water properties, which has a positive impact on the taste of served beverages. The product reduces the concentration of chlorine in the water, and thanks to the use of ScaleStop technology, it also protects equipment against limescale.

- ✔ Quick and easy replacement
- ✔ Reduces chlorine concentration
- ✔ Improves taste and smell
- ✔ ScaleStop Technology

The ONE C filter is a versatile solution for water treatment. The product is recommended for coffee makers, vending machines, water dispensers and combi-steam ovens.



| | |
|--------------------|------------------------|
| Operating pressure | 0.7-8.6 bar |
| Water temperature | 4-55°C |
| Flow rate | 4 L/min |
| Capacity | 18500 L@85 %* |
| Cartridge size | Ø 13.70 cm x H 36 cm |
| Certificates | PZH-NIH, NSF**/ANSI 42 |

* chlorine reduction
 ** NSF certification possible on request

ONE MB

The ONE MB filters are designed for full water demineralisation and reduction of salt concentrations. It is the perfect solution for small dishwashers, coffee makers, and combi-steam ovens. Multi-step filtration reduces sediments, chlorine, as well as calcium and magnesium compounds. Glass is free of streaks and does not require wiping. Perfect froth on beer and sparkling wine. Lower use of detergents.

- ✔ Quick and easy replacement
- ✔ Reduces chlorine concentration
- ✔ Reduces mineral salt concentrations
- ✔ Improves taste and smell
- ✔ Water demineralisation
- ✔ Glass without streaks

The ONE MB filter is designed for small glassware dishwashers.



| | |
|--------------------|------------------------|
| Operating pressure | 0.7-8.6 bar |
| Water temperature | 4-38°C |
| Flow rate | 2 L/min |
| Cartridge size | Ø 13.70 cm x H 36 cm |
| Certificates | PZH-NIH, NSF**/ANSI 42 |

* chlorine reduction
 ** NSF certification possible on request



Bypass head

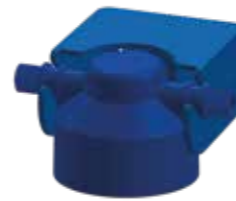

Non-bypass head



ADVANTAGES

APPLICATIONS

TECHNICAL SPECIFICATIONS



ONE FILTERS

ADVANTAGES

APPLICATIONS

TECHNICAL SPECIFICATIONS

ONE MG+

ONE MG+ is an innovative solution with the Mg+ water mineralization technology. The filter replenishes water with minerals which are indispensable for the improvement of raw water quality. This makes beverages tastier and healthier. The product ideal for the preparation of tea, coffee, and other cold and hot beverages. Thanks to balanced water pH, it gives the perfect froth on espresso coffee.

- ✔ Quick and easy replacement
- ✔ Reduces chlorine concentration
- ✔ Improves taste and smell
- ✔ Mg+ water mineralization
- ✔ Stabilizes water pH

The ONE MG+ filter is a versatile cartridge with technology to enrich water with magnesium.



| | |
|--------------------|------------------------|
| Operating pressure | 0.7-8.6 bar |
| Water temperature | 4-55°C |
| Flow rate | 4 L/min |
| Capacity | 6000 L@85%* |
| Cartridge size | Ø 13.70 cm x H 36 cm |
| Certificates | PZH-NIH, NSF**/ANSI 42 |

* chlorine reduction

** NSF certification possible on request

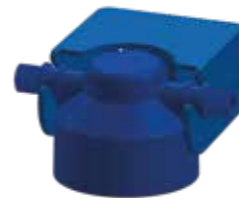

Non-bypass head

ONE SOFT

The ONE SOFT filter series are designed for water optimization in food service (HoReCa). The series is an excellent solution for raw water hardness reduction and chlorine content reduction. The filters reduce hardness in a hydrogen cycle. The taste and smell of water are also improved. High-efficiency protection against limescale for all types of food service equipment which requires water treatment.

- ✔ Quick and easy replacement
- ✔ Reduces water hardness in a hydrogen cycle
- ✔ NSF / ANSI 42 certified

The ONE SOFT filter is primarily designed to combi-steam ovens, coffee makers, water dispensers and ice makers.

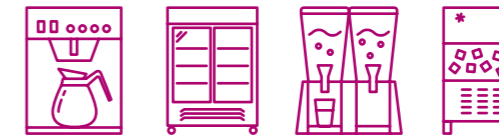

| | |
|--------------------|-------------------------|
| Operating pressure | 0.7-8.6 bar |
| Water temperature | 2-38°C |
| Flow rate | 2 L/min |
| Cartridge size | Ø 13.70 cm x H 43.20 cm |
| Certificates | PZH-NIH, NSF**/ANSI 42 |

* chlorine reduction

** NSF certification possible on request



Bypass head



ADVANTAGES

APPLICATIONS

TECHNICAL SPECIFICATIONS



ONE FILTERS

ADVANTAGES

APPLICATIONS

TECHNICAL SPECIFICATIONS

ONE UF

The ONE UF series filters ensure optimum protection against microorganisms, including bacteria. The products provide filtration at the level of 0.1 um through the use of an ultra-filtration membrane. The filters provide the feeling of safety when consuming drinks. They protect the system against limescale thanks to the latest ScaleStop technology. The products provide highly efficient water treatment and protection against limescale for all types of food service devices requiring water treatment.

- ✔ Quick and easy replacement
- ✔ 0.1 um filtration, LOG7
- ✔ Reduces chlorine concentration
- ✔ Improves taste and smell
- ✔ ScaleStop Technology

The ONE UF filter is recommended for ice makers, coffee makers, and vending machines.



| | |
|--------------------|------------------------|
| Operating pressure | 0.7-8.6 bar |
| Water temperature | 4-38°C |
| Flow rate | 4 L/min |
| Capacity | 8000 L@85 %* |
| Cartridge size | Ø 13.70 cm x H 36 cm |
| Certificates | PZH-NIH, NSF**/ANSI 42 |

* chlorine reduction

** NSF certification possible on request

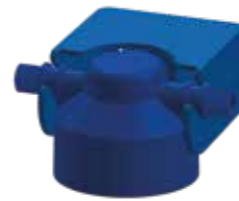

Non-bypass head

ONE LEAD

The ONE LEAD filtration system uses innovative technology for the removal of toxic compounds and heavy metals from water. It reduces concentrations of heavy metals, including: Pb, Hg, Cr, Mg, Ni, Co, Ba, Sr, Zn, and Au. The system is ideally suited to older installations with steel pipe components. The system will also remove chlorine from water, which will improve its taste and smell. The product provides water filtration at the level of 5um with a low pressure drop.

- ✔ Quick and easy replacement
- ✔ Reduces chlorine concentration
- ✔ Improves taste and smell
- ✔ Reduces heavy metal concentrations, including:
Pb, Hg, Cr, Mg, Ni, Co, Ba, Sr, Zn, and Au
- ✔ Low pressure drop

The ONE LEAD filter is the perfect solution for ice makers, coffee makers, and water dispensers.

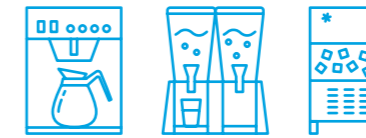

| | |
|--------------------|------------------------|
| Operating pressure | 0.7-8.6 bar |
| Water temperature | 2-38°C |
| Flow rate | 4 L/min |
| Capacity | 3000 |
| Cartridge size | Ø 13.70 cm x H 36 cm |
| Certificates | PZH-NIH, NSF**/ANSI 42 |

** NSF certification possible on request

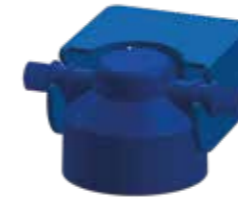

Non-bypass head



ADVANTAGES

APPLICATIONS

TECHNICAL SPECIFICATIONS





What is reverse osmosis?

The phenomenon of reverse osmosis, as the name suggests, is a reversal of a natural process, which consists in the diffusion of a solvent through a semi-permeable membrane separating two solutions with different concentration. The process leads to the equalisation of concentrations of two solutions mixed together. The reversed process consists in a forced diffusion of the solvent through a semi-permeable membrane separating two different solutions. As a result, an increase in the difference of concentration separating both substances is obtained.

Our industrial reverse osmosis devices are compact solutions that do not take up a lot of room, allowing them to be used in almost any system. They are efficient and can operate in continuous duty, ensuring constant demineralised water production, and reducing consumption of cleaning and washing chemicals. The glasses are crystal clean and the cutlery is shiny. They require minimum maintenance, and their operation diagnostics are very simple.

REVERSE OSMOSIS

- RO SMART
- RO AQUAMATIC
- RO AQUABOX

RO SMART

The RO SMART reverse osmosis system is a water treatment solution for applications requiring water with low conductivity and high workload.

- System capacity: 120 L/h*, 150 L/h*, 180 L/h*.
- Recovery rate: from 25% to 60%.
- Salt removal: 95%.

*depending on model ** at supply water temp. 15° C

Supply water requirements



Water quality: Potable



Water temperature: 5-30°C



Min. influx: 600 L/h



Pressure: 3 bar

- In medicine, healthcare and laboratory use for cleaning glass, etc. In combination with final demineralisation systems (MB), completely demineralised water is obtained for sterilizers.
- In the HORECA sector, RO SMART is the safest and the most durable system for dishwashers equipped with an expansion tank.
- In all applications for the cleaning of tools, metal surfaces, glassware, glazing units and solar panels.

The RO SMART reverse osmosis system removes minerals and calcium from water to guarantee excellent cleaning results, without the need for polishing.

- ✔ No limescale = prolonged equipment lifetime.
- ✔ Modern design.
- ✔ Stainless steel housing.
- ✔ Full control of operation.
- ✔ High efficiency and water quality.

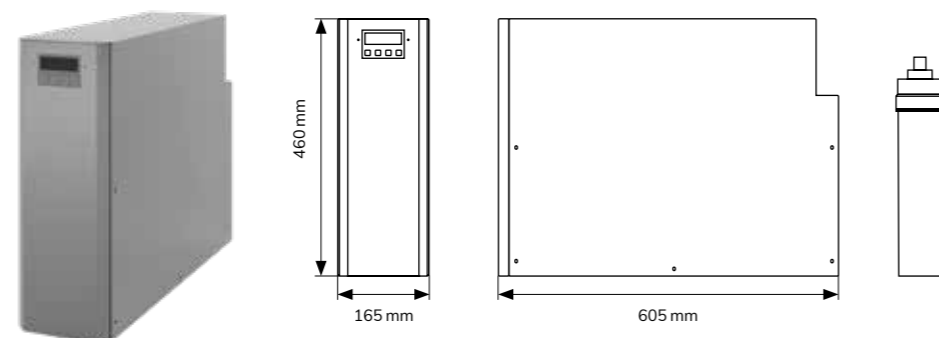

Reverse osmosis

- **Prefilter:** The prefiltration system reduces and removes cloudiness present in water, removes chlorine and improves the taste and smell of water. Its nominal filtration efficiency is 5 microns.
- **Microprocessor controller:** Enables full control over the device's operation. The user friendly, intuitive menu displays all crucial operating data and the current work status. It provides access to work statistics, collects data on water consumption, and instructs the user to perform system maintenance or replace the cartridge.
- **Pressure pump:** The efficient pressure pump extends the lifetime of the device.
- **Water conductivity measurement:** The device continuously measures the quality of treated water and (optionally) raw water. It is possible to set alarm thresholds for the conductivity of treated and raw water.

APPLICATIONS

ADVANTAGES

TECHNICAL SPECIFICATIONS

| | RO SMART 120 | RO SMART150 | RO SMART 180HF |
|--|---|-------------|----------------|
| Prefilter operation time: | max. 80 h (depending on supply water quality) | | |
| Reverse osmosis membrane operation time: | until clogged | | |
| Noise level: | <70 (dB (A)) | | |
| Number of membranes: | 4 x 150 GPD | 2 x 300 GPD | 2 x 500 GDP |
| Prefilter type: | 5-micron carbon block | | |
| Weight: | 15 kg | 18 kg | 18 kg |
| Power supply: | 230/50 Hz | | |
| Power consumption: | 1.2 A | | |
| Power output: | 150 W | 250 W | 300 W |
| Capacity: | 120 L/h | 150 L/h | 180 L/h |

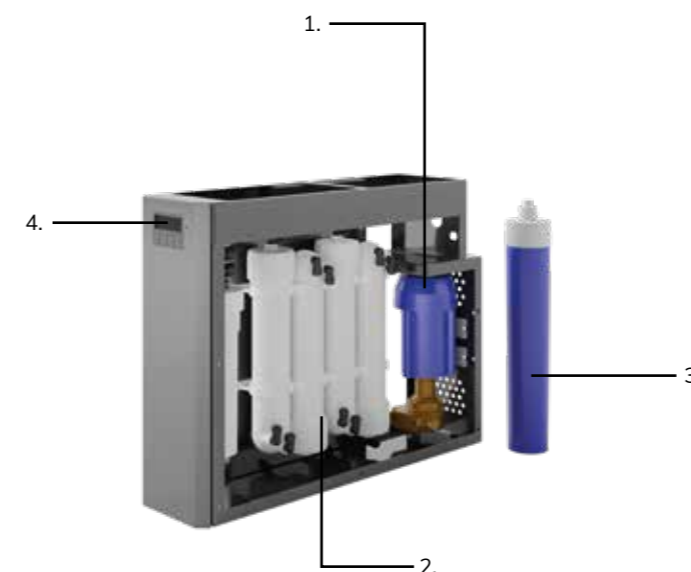

- 1. Pump
- 2. Membranes
- 3. Prefilter
- 4. Electronic display

RO AQUAMATIC

The RO AQUAMATIC reverse osmosis system is a water treatment solution for applications requiring water with low conductivity and high workload.

- System capacity: 150 L/h* and 350 L/h*.
- Recovery rate: from 25% to 60%.
- Salt removal: 95%.

*depending on model ** at supply water temp. 15° C

Supply water requirements



Water quality:
Potable



Water temperature:
5-30°C



Min. influx:
600 L/h



Pressure:
3 bar

- In medicine, healthcare and laboratory use for cleaning glass, etc. In combination with final demineralisation systems (MB), completely demineralised water is obtained for sterilizers.
- In the HORECA sector, AQUAMATIC is the safest and the most durable system for dishwashers equipped with an expansion tank.
- In all applications for the cleaning of tools, metal surfaces, glassware, glazing units and solar panels.

The AQUAMATIC reverse osmosis system removes minerals and calcium from water to guarantee excellent cleaning results, without the need for polishing.

- ✔ No limescale = prolonged equipment lifetime.
- ✔ Modern design.
- ✔ Stainless steel housing.
- ✔ Full control of operation.
- ✔ High efficiency and water quality.

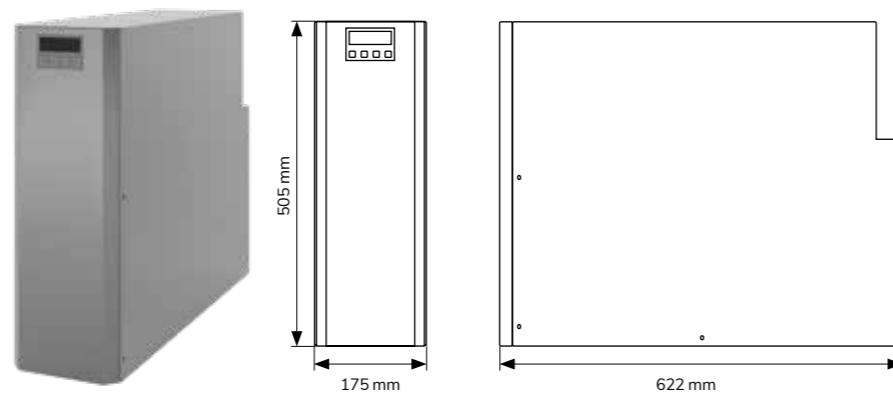

Reverse osmosis

• **Prefilter:** The prefiltration system reduces and removes cloudiness present in water, removes chlorine and improves the taste and smell of water. Its nominal filtration efficiency is 5 microns.

• **Microprocessor controller:** Enables full control over the device's operation. The user friendly, intuitive menu displays all crucial operating data and the current work status. It provides access to work statistics, collects data on water consumption, and instructs the user to perform system maintenance or replace the cartridge.

• **Pressure pump:** The use of an efficient pressure pump extends the lifetime of the device.

• **Water conductivity measurement:** The device continuously measures the quality of treated water and (optionally) raw water. It is possible to set alarm thresholds for the conductivity of treated and raw water.

| | AQUAMATIC 150 | AQUAMATIC 200 | AQUAMATIC 250 HF | AQUAMATIC 350 HF |
|--|---|---------------|------------------|------------------|
| Prefilter operation time: | max. 80 h (depending on supply water quality) | | | |
| Reverse osmosis membrane operation time: | until clogged | | | |
| Noise level: | <70 (dB (A)) | | | |
| Number of membranes: | 2 x 300 GPD | 3 x 300 GPD | 2 x 500 GDP | 3 x 500 GDP |
| Prefilter type: | 5-micron carbon block | | | |
| Weight: | 22 kg | 25 kg | 22 kg | 25 kg |
| Power supply: | 230/50 Hz | | | |
| Power consumption: | 1.2 A | | | |
| Power output: | 250 W | | | |
| Capacity: | 150 L/h | 200 L/h | 250 L/h | 350 L/h |

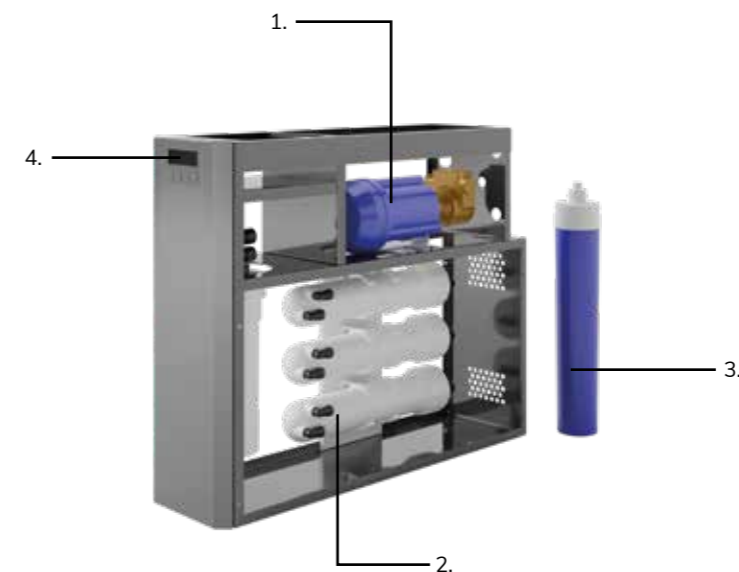

1. Pump
2. Membranes
3. Prefilter
4. Electronic display

RO AQUABOX

The RO AQUABOX reverse osmosis system is a water treatment solution for applications requiring water with low conductivity and high workload.

- System capacity: 250 L/h* and 350 L/h*.
- Recovery rate: from 25% to 60%.
- Salt removal: 95%.

*depending on model ** at supply water temp. 15° C

Supply water requirements



Water quality:
Potable



Water temperature:
5-30°C



Min. influx:
600 L/h



Pressure:
3 bar

- In medicine, healthcare and laboratory use for cleaning glass, etc. In combination with final demineralisation systems (MB), completely demineralised water is obtained for sterilizers.
- In the HORECA sector, AQUABOX is the safest and the most durable system for glassware dishwashers.
- In all applications for the cleaning of tools, metal surfaces, glassware, glazing units and solar panels. The AquaBox system is supplied with a water storage tank (optional equipment).

The AQUABOX reverse osmosis system removes minerals and calcium from water to guarantee excellent cleaning results, without the need for polishing.

- ✔ No limescale = prolonged equipment lifetime.
- ✔ Modern design.
- ✔ Stainless steel housing.
- ✔ Full control of operation.
- ✔ High efficiency and quality of water from a small device.

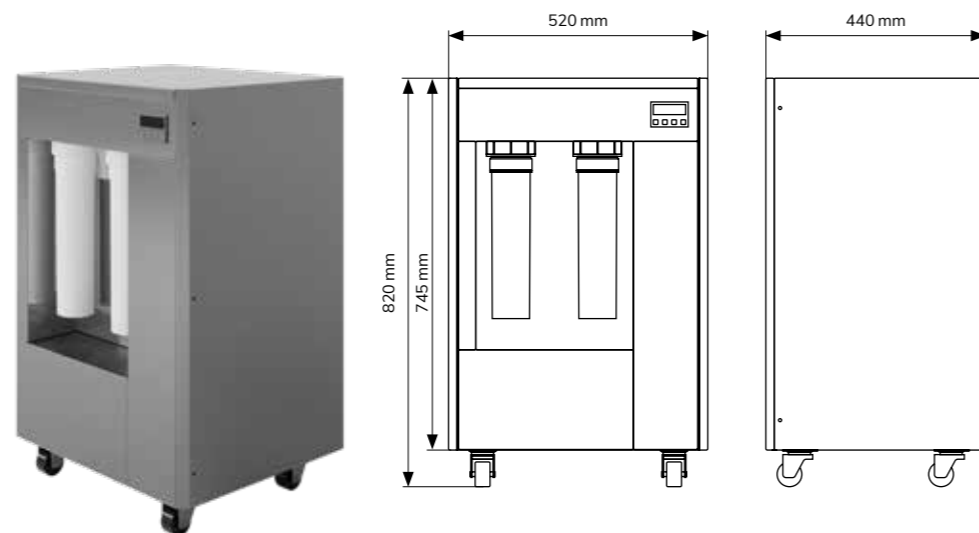

- **Prefilter:** The prefiltration system reduces and removes cloudiness present in water, removes chlorine and improves the taste and smell of water. Its nominal filtration efficiency is 5 microns.
- **Microprocessor controller:** Enables full control over the device's operation. The user friendly, intuitive menu displays all crucial operating data and the current work status. It provides access to work statistics, collects data on water consumption, and instructs the user to perform system maintenance or replace the cartridge.
- **Pressure pump:** The use of an efficient pressure pump extends the lifetime of the device.
- **Water conductivity measurement:** The device continuously measures the quality of treated and raw water (option). It is possible to set alarm thresholds for the conductivity of treated and raw water. The storage tank inside the device enables the supply of water at the pressure of approx. 2.5 bar. (optional)

APPLICATIONS

ADVANTAGES

| | AQUABOX 250 | AQUABOX 350 |
|--|---|-------------|
| Prefilter operation time: | max. 80 h (depending on supply water quality) | |
| Reverse osmosis membrane operation time: | until clogged | |
| Noise level: | <70 (dB (A)) | |
| Number of membranes: | 4 x 300 | 5 x 300 |
| Prefilter type: | 2 x 5-micron carbon block | |
| Weight: | approx. 50-60 kg | |
| Power supply: | 230/50 Hz | |
| Power output: | 550 W | |
| Capacity: | 250 L/h | 350 L/h |



1. Pump
2. Membranes
3. Prefilter
4. Electronic display



Water softening is removal of unwanted minerals from water, primarily calcium and magnesium.

This is because calcium and magnesium compounds contribute to the formation of limescale and increase water hardness. Soft water produced by softening treatment extends the lifetime of the equipment and reduces power consumption. It enhances the quality of meals and beverages served. It reduces the consumption of cleaning agents. It also increases the efficiency of devices and equipment. It is the healthy choice for you and your clients.

WATER SOFTENERS

- Junior ECO 04 M / Junior ECO 08 M
- Junior ECO 04 VC / Junior ECO 08 VC
- Minisoft 15 / 20
- Best ONE SOFT

Junior ECO 04 M / ECO 08 M

JUNIOR ECO 04 M is a compact, semi-automatic water softener with very small dimensions, designed specifically for small installation spaces. It can supply water to one or several water receivers. The device regeneration is initiated manually. A salt solution is used as the consumable. Installation of a prefilter upstream of each softener is recommended for protection of the control head.

- ✔ Good performance to price ratio
- ✔ Small overall size
- ✔ Low operating costs
- ✔ Soft water for many applications



| | | JUNIOR ECO 04 M | JUNIOR ECO 08 M |
|--|------|--------------------|--------------------|
| Max. flow at <0.1 °d hardness | m³/h | 0.3 | 0.6 |
| Water volume before regeneration at raw water hardness 15 ° dH | L | 800 | 1600 |
| Operating medium volume | L | 4 | 8 |
| Operating pressure | bar | 2.5-6 | |
| Max. water temperature | °C | 38 | |
| Nominal connection diameter | DN | 20 | 20 |
| Total height | mm | 500 | 600 |
| Total width | mm | 180 | 240 |
| Depth | mm | 330 | 450 |
| Power supply | V/Hz | 230/50 | |
| Working voltage | V | 12 | |

Junior ECO 04 VC / ECO 08 VC

A compact, fully automatic water softener with very small dimensions, designed specifically for small installation spaces. It can supply water to one or several water receivers. The automatic control head with a built-in electronic water meter monitors water consumption and commences the regeneration process as required. The device regeneration is automatic and initiated by the microprocessor of the control head. A salt solution is used as the consumable. We recommend the installation of a prefilter before each softener in order to protect the control head.

- ✔ Good performance to price ratio
- ✔ Small overall size
- ✔ Low operating costs
- ✔ Soft water for many applications



| | | JUNIOR ECO 04 VC | JUNIOR ECO 08 VC |
|--|------|---------------------|---------------------|
| Max. flow at <0.1 °d hardness | m³/h | 0.3 | 0.6 |
| Water volume before regeneration at raw water hardness 15 ° dH | L | 800 | 1600 |
| Operating medium volume | L | 4 | 8 |
| Operating pressure | bar | 2.5-6 | |
| Max. water temperature | °C | 38 | |
| Nominal connection diameter | DN | 20 | 20 |
| Total height | mm | 500 | 600 |
| Total width | mm | 180 | 240 |
| Depth | mm | 330 | 450 |
| Power supply | V/Hz | 230/50 | |
| Working voltage | V | 12 | |



WATER SOFTENERS

FEATURES AND ADVANTAGES

TECHNICAL SPECIFICATIONS

Minisoft 15 / 20

Automatic MINISOFT 15 and 20 water softeners feature a compact housing. They are available with an automatic, electronically-controlled head.

- ✔ The smallest water softener on the market
- ✔ Compact, fully automatic and easy to use
- ✔ Regenerated by volume, according to water consumption



| | | MINISOFT 15 | MINISOFT 20 |
|---|-------------------|-------------|-------------|
| Max. flow at <math><0.1\text{ }^{\circ}\text{d}</math> hardness | m ³ /h | 0.5 | 0.7 |
| Water volume before regeneration at raw water hardness 15 °dH | L | 900 | 1200 |
| Operating medium volume | L | 5 | 6.5 |
| Operating pressure | bar | 2.5-6 | |
| Max. water temperature | °C | 38 | |
| Nominal connection diameter | DN | 20 | 20 |
| Total height | mm | 550 | 560 |
| Total width | mm | 300 | 300 |
| Depth | mm | 400 | 400 |
| Power supply | V/Hz | 230/50 | |
| Working voltage | V | 12 | |

Best ONE SOFT

The BEST ONE SOFT filters are designed for water optimisation in food service (HoReCa). The series is an excellent solution for raw water hardness reduction and chlorine content reduction. The filters reduce hardness in a hydrogen cycle. The taste and smell of water are also improved. The filters provide high-efficiency protection against limescale for all types of food service devices requiring water treatment.

- ✔ Hardness reduction in a hydrogen cycle
- ✔ Easy and simple cartridge replacement
- ✔ Does not generate sewage
- ✔ High efficiency of 15,000 L
- ✔ Expandable system design



| Raw water hardness CaCO ₃ | BEST ONE SOFT cartridge |
|---|----------------------------|
| 180 ppm | 15,000 L* |

* the amount of treated water between replacements depends on raw water parameters

FEATURES AND ADVANTAGES

TECHNICAL SPECIFICATIONS





ACCESSORIES

- iMeter
- iHub
- Total Hardness Tester
- Salt tablets
- Conductivity tester for water quality checks

ACCESSORIES

FEATURES AND ADVANTAGES

iMeter

The iMeter flow meter works by wireless data transmission. It enables data transfer from the flow meter to the mobile app.

- Filter cartridge operation time monitoring with a programmed volume from 1 to 1,000,000 litres.
- Two LED indicators of the filter and battery status.
- Filter cartridge change alarm
- Easy volume readout via the iMeter app on your smartphone. The iMeter app can be downloaded free from Apple Store and Android Play.
- The iMeter app automatically transmits filter throughput data to the cloud management system.
- Powered by two alkaline AA batteries. Battery life is in excess of a year for home applications.
- Low battery level alarm



iHub





- iHubb is a small handy device expanding the capabilities of iMeter. Its operation requires iMeter.
- iHubb requires WiFi connection with any bandwidth in order to work.
- Up to 8 iMeters can connect with one iHubb at the same time
- iHubb connects with the cloud via WiFi, allowing the user to review current iMeter data through a data acquisition portal
- Each device with WiFi can access the flow meter data through a unique client login



FEATURES AND ADVANTAGES

iMeter Cloud management system.

IoT Solutions

-  Easy access to filter usage and efficiency data.
-  Live transmission of filter usage / capacity data to the cloud management system.
-  In-app alarm / notification about filter depletion Cloud Management System
-  Water consumption statistics for each user. The users have a full overview of the filter operation.

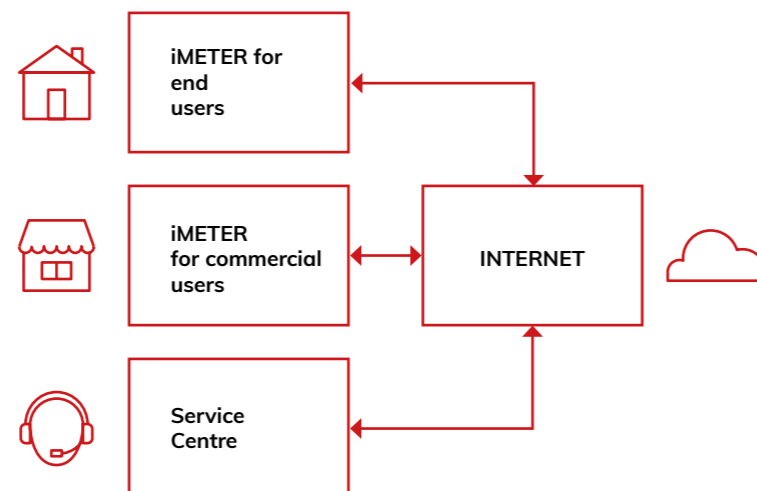

iMETER model details

| | |
|-------------------------|--|
| Volume | 1 - 999,999 litres |
| Unit | Litre / Gallon |
| Transmission | Bluetooth BLE 4.2 |
| Power supply | 3V DC (2 AA alkaline batteries) |
| Flow range & connection | BT-058(L)-32 1/4" 0.2-5 LPM BT-058(L) 1/4" 0.6 -8 LPM BT-058(L)-22 3/8" 0.8 -15 LPM BT-058(L)-44 1/2" 1.5 - 25 LPM BT-058(L)-66 3/4" 2 -60 LPM BT-058(L)-88 1" 3 - 100 LPM |
| Alarm | Filter cartridge depletion alarm. Low battery alarm |
| Cable length | 1.5 m |

Total Hardness Tester

Treated water must be tested for the periodic inspection of operation of every water softener. The tests are done with the Total Hardness Tester.



Salt tablets

Salt is a consumable necessary for the softener regeneration process. Without the salt, the system will not be able to produce a suitable brine concentration, which will result in hard water production, and eventually to limescale in downstream equipment.



Conductivity tester for water quality checks

AP-2 CONDUCTIVITY METER.

This pocket conductivity tester measures the conductivity and temperature of liquids. The conductivity meter is highly useful in fishkeeping, cosmetic and beauty parlours, medical settings, analytical laboratories, and many more applications. The meter features a high measurement precision thanks a microchip controller. The conductivity meter has a built-in magnet for attachment to a refrigerator or other metal surfaces. Automatic temperature compensation (APC) between 1 and 50°C.

- Memory hold function
- Water resistant to 90% of its height
- 5-minute auto off for increased battery life
- Built-in digital thermometer
- Temperature indication in °C and °F
- Simultaneous display of conductivity and temperature results: no need to switch between the functions
- Factory calibrated in a 700 µS NaCl solution
- Button-operated digital calibration routine
- Large and clear LCD screen
- Switches off automatically after 5 minutes of inactivity
- 2-year warranty

- Conductivity measurement range: 0-9999 µS/cm
- Resolution from 0 to 999: 1 µS
- Resolution from 1000 to 9999: 1 µS
- Measurement tolerance: +/- 2%
- Temperature measurement range: 0-80°C or 32-176°F
- Thermometer resolution: 0.1
- Power supply: 1 battery 3 V (included)
- Average battery life: 2 years
- Device dimensions [cm]: 15 x 2.8 x 1.3
- Device dimensions [inch]: 5.9 x 1.1 x 0.5
- Weight without box: 42.5 g



DESCRIPTION

SPECIFICATION

- Product contents.**
- EC AquaPro AP2 meter with a protective electrode cap
 - 3 V battery (installed)
 - Stylish plastic gift case
 - User manual

Are you looking for a solution dedicated to your company?

We offer dedicated systems, central water treatment plants and OEM solutions tailored to customer needs.

Contact the Watersystem Sales Department and we will develop a solution customized for you.



Dosing and dilution systems

www.aquaclean24.pl

Multimedia fountains

www.fontannyinteraktywne.pl

Sewage treatment

www.sciekiprzemyslowe.com.pl



www.watersystem.com.pl

Watersystem
ul. Trakt Brzeski 127,
Zakręt 05-077 Warszawa (Warsaw)

email:
watersystem@watersystem.pl

 [watersystem](https://www.facebook.com/watersystem)

Phone:
+48 22 773-23-80
+48 22 795-77-93
+48 22 425-78-99

Fax:
+48 22 773-23-80
+48 22 357-93-39